

VOLTAGE		
Field selectable to match power source of 12, 16, or 24 VAC/VDC.		
CURRENT DRAW/AMPS		
Volts	AC	DC
12	.163	.440
16	.228	.458*
24	.084	.230

*Requires 16 VDC adapter (P/N VA 7400-16VDC)

Opens electrically under 35lbs. of preload!

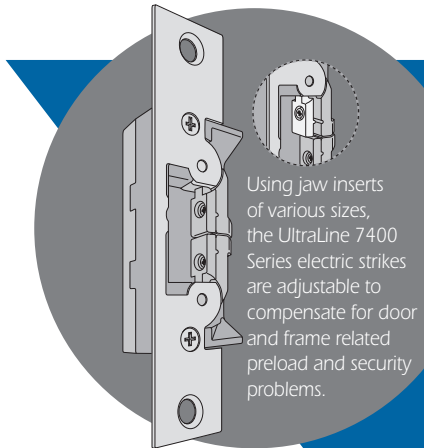

Listed for Burglary Resistance (UL1034)

Case

Approx. 1" x 3-3/8" x 1-1/16" deep.
Zinc-aluminum alloy.

Strike Lip

Basic 7400 strike has lip of proper length 1-3/4" thick door that closes flush with jamb edge. Where door thickness or jamb shape differs from this standard relationship, lip extension kits available.

Fail-Safe/Fail-Secure

Field selectable at time of installation.

Strike Opening

5/8" Adjustable x 1-7/16" x 1/2" deep. Bolt retainer jaw is stainless steel.

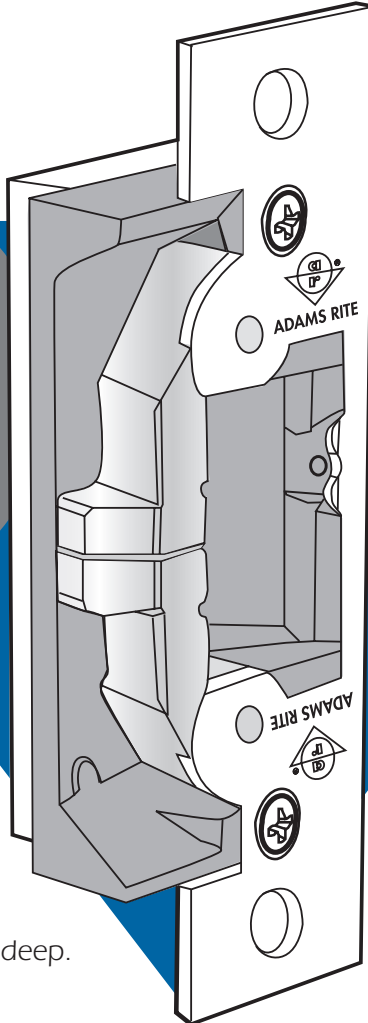

ULTRA LINE

7440

ANSI/BHMA Type EO9321 (Grade 1)

LATCH TYPE

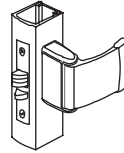

Adams Rite or Cylindrical Latches with 1/2" to 5/8" Projection

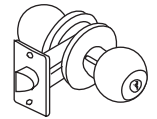

DOOR FRAME/DOOR TYPE

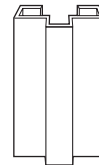

Hollow Metal



Wood

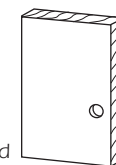

Steel Door or Wood Door*

*Requires WDC7400

Faceplate

Measures 1-1/4" x 4-7/8". Faceplate is flat, with square corners. Available in a wide range of architectural finishes.

Function

Remote electrical control of any door equipped with "key-in-lever/cylindrical" type latchsets listed above. Electrical actuation unlocks strike jaw, releasing latchbolt, so door can be opened without operating latch itself. Extremely compact mechanism fits into jamb sections as shallow as 1-1/16". Fits existing preps for 7840AN and 7850/7040/7140.

This non-handed strike features an ultra-compact design and an adjustable stainless steel split-jaw with over 2400lbs. of holding force. The strike releases electrically with up to 35lbs. of door "preload" (pressure exerted on doors by air conditioning systems, warping or misaligned hardware which can disable common electric strikes). Single solenoid operates on 12, 16, or 24 volt AC/DC power. Strikes are equipped with a quick connect plug-in type connector.



7440 Electric Strike

DIMENSIONS

INCHES
MILLIMETERS

Nominal, subject to tolerance extremes.

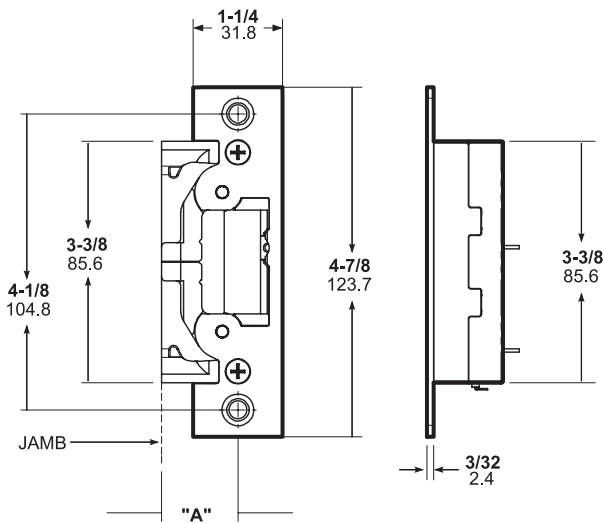
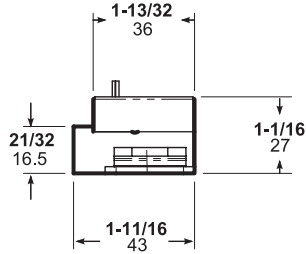

STANDARD UNIT FITS DIM "A" 1-1/16" (SEE DASH NO.)
MOUNTING BACKSETS FURNISHED

INSTALLATION

Jamb Preparation

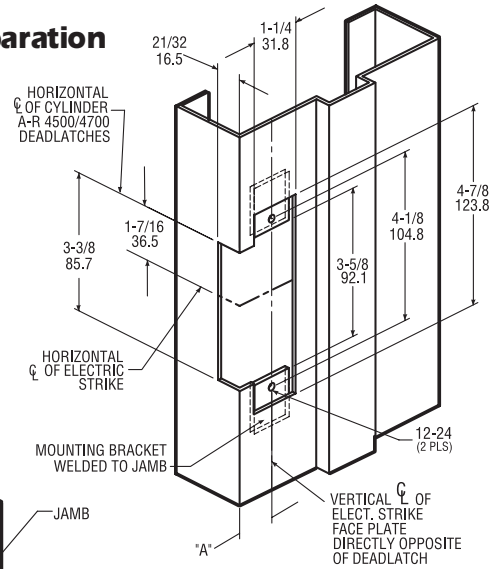

Installation

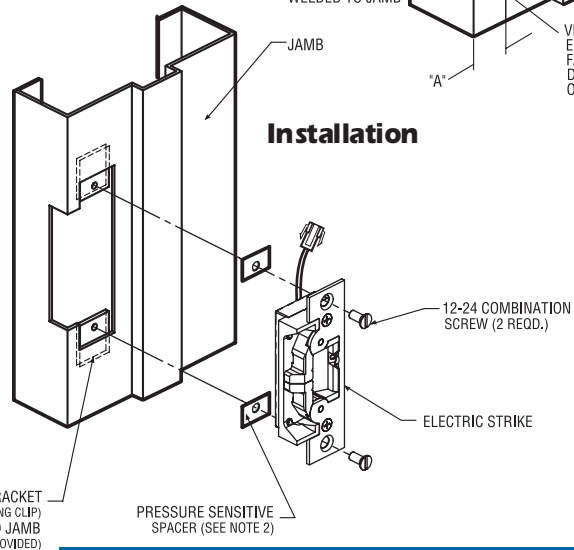

HOW TO ORDER

Specify quantity and the following information.
Order related hardware separately.

Fail-secure can be field converted
to fail-safe or vice-versa.

Options

- None
- M** Monitored

7440 M 628

Finish

- 628** Clear Anodized
- 605** Bright Brass
- 606** Satin Brass
- 611** Bright Bronze
- 612** Satin Bronze
- 313** Dark Bronze Anodized
- 335** Black Anodized
- 629** Bright Stainless
- 630** Satin Stainless

STANDARD PACKAGE

Individually boxed with mounting screws. Includes mounting clips and adhesive shims for use where welded tabs are omitted. Also included is an adjustable jaw shim pack and two plug-in voltage adapters for 12/16/24 VAC and 12/24 VDC.

OPTIONS

Monitoring - Two internally mounted switches (Form "C") to indicate when the latchbolt is engaged in the strike jaws and a locked/unlocked solenoid status. See page A-16 for more details.

Power Sources - 4605/4606 Transformer, 4603 Rectifier, and PS-1 Power Supply. See page A-16 for more details.

Lip Extension Kits - See page AC-16 for a complete list.

Modular Packaging - Consult factory or sales representative for details.

Wood Door Cover - WDC7400 for use when mounting the 7400 series on the inactive leaf of pairs. The cover simplifies the mortise prep.

ELX-ElectroLynx™ Adapter - Connects Adams Rite electrified products to ElectroLynx system.

16 VDC Adapter - VA7400-16VDC required when using 16VDC power.